

*made to measure*

# OPERATING INSTRUCTIONS AND SYSTEM DESCRIPTION OF THE **TURBO TEC-10CX** **TWO ELECTRODE CLAMP SYSTEMS**



**VERSION 2.8**  
**npi 2013**

**npi electronic GmbH**, Bauhofring 16, D-71732 Tamm, Germany  
Phone +49 (0)7141-9730230; Fax: +49 (0)7141-9730240  
support@npielectronic.com; <http://www.npielectronic.com>

# TABLE of CONTENTS

<b>TABLE OF CONTENTS</b> .....	<b>2</b>
<b>0 SAFETY REGULATIONS</b> .....	<b>4</b>
<b>1 INTRODUCTION</b> .....	<b>5</b>
<i>About this Manual</i> .....	5
<i>Important Literature</i> .....	5
<i>Software</i> .....	5
<i>CellWorks Software</i> .....	
<b>2 SYSTEM DESCRIPTION</b> .....	<b>6</b>
2.0 GENERAL DESCRIPTION .....	6
<i>Selection and Options</i> .....	6
<i>Accessories</i> .....	6
2.1 POTENTIAL REGISTRATION.....	7
<i>Arrangement of the Recording Electrodes</i> .....	7
<i>Capacity Compensation</i> .....	7
<i>Offset Compensation</i> .....	7
<i>Current Electrode Potential Recording</i> .....	8
<i>Potential Monitor and Audio Monitor</i> .....	8
2.2 CURRENT INJECTION AND CURRENT MEASUREMENT .....	8
<i>Current Injection</i> .....	8
<i>Output Current Zero (C. HEADSTAGE BIAS CURRENT)</i> .....	8
<i>Current Injection Bandwidth</i> .....	9
<i>Capacity Compensation (current electrode, optional)</i> .....	9
<i>Current Range</i> .....	9
<i>Current Measurement</i> .....	10
<i>Current Monitor and Current Output Sensitivity</i> .....	10
<i>Transient Compensation (TEC 10CX)</i> .....	10
<i>Current Filter</i> .....	10
<i>Options</i> .....	11
2.3 ELECTRODE RESISTANCE MEASUREMENT .....	11
2.4 CURRENT CLAMP MODE (CC).....	12
<i>Current Clamp Inputs</i> .....	12
2.5 VOLTAGE CLAMP MODE (VC) .....	12
<i>Voltage Clamp Inputs</i> .....	12
<i>Rise Time Control</i> .....	12
<i>Control Circuit (P-I controller)</i> .....	12
<i>VC Error Display</i> .....	13
<i>Current Limit (VC OUTPUT LIMIT)</i> .....	13
<i>Series Resistance Compensation</i> .....	13
<i>Low Noise Mode</i> .....	13
<i>Improvement of the Control Properties</i> .....	14
2.6. ADDITIONAL SYSTEMS .....	14
<i>Audio Monitor</i> .....	14
<i>Oscillation Shut-Off</i> .....	14

2.7 DIGITAL CONTROL UNIT .....	15
<i>Mode of operation selection</i> .....	15
<b>3 CONTROLS AND CONNECTORS .....</b>	<b>16</b>
3.1 FRONT PANEL.....	16
<i>TEC-05X option</i> .....	17
3.2. REAR PANEL .....	17
3.3. POTENTIAL HEADSTAGE.....	18
<i>TEC-05X option</i> .....	18
3.4. CURRENT HEADSTAGE .....	18
<b>4 INSTALLATION.....</b>	<b>19</b>
4.1. GENERAL CONSIDERATIONS.....	19
<i>Safety</i> .....	19
<i>Prevention of Line Interference</i> .....	19
4.2. TESTS AND TUNING PROCEDURES .....	20
<i>General Considerations</i> .....	20
<i>Basic connections</i> .....	20
<i>TEC Cell Model</i> .....	20
<i>Adjustment of the CURRENT HEADSTAGE BIAS CURRENT control</i> .....	20
<i>Test of the Current Clamp Mode</i> .....	21
<i>Test of the Voltage Clamp Mode</i> .....	21
<i>Testing of the Zero Current / Zero Potential</i> .....	22
<i>Resistance Measurement</i> .....	22
<i>Adjustment and Test of the Transient Compensation (TEC 10CX)</i> .....	22
<i>Oscillation Shut-Off</i> .....	22
<b>5 CONTROL THEORY APPENDIX.....</b>	<b>23</b>
5.1 THEORY OF OPERATION OF THE TEC SERIES AMPLIFIERS .....	23
EMPIRICAL TUNING PROCEDURE FOR PI CONTROLLERS .....	25
5.3 SPEED OF RESPONSE AND LINEARITY OF THE CAPACITIVE TRANSIENTS.....	25
<b>6 REFERENCES .....</b>	<b>28</b>
<b>7 TURBO TEC SERIES SPECIFICATIONS.....</b>	<b>31</b>

# 0 SAFETY REGULATIONS

**VERY IMPORTANT:** Instruments and components supplied by npi electronic are NOT intended for clinical use or medical purposes (e.g. for diagnosis or treatment of humans), or for any other life-supporting system. npi electronic expressly disclaims any warranties for such purpose. Equipment supplied by npi electronic shall be operated only by selected, trained and adequately instructed personnel. For details please consult the GENERAL TERMS OF DELIVERY AND CONDITIONS OF BUSINESS of npi electronic, D-71732 Tamm, Germany.

**GENERAL:** This system is designed for use in scientific laboratories and should be operated by trained staff only. General safety regulations for operating electrical devices are to be considered.

**AC MAINS CONNECTION:** In working with instruments and components supplied by npi electronic, always adhere to the appropriate safety measures for handling electronic devices. Before using any device please read manuals and instructions carefully.

Always use a three-wire line cord and a mains power-plug with a protection contact connected to mains ground (protective earth).

Check for appropriate line voltage before connecting any system to mains.

Before opening the cabinet disconnect mains power-plug.

Disconnect mains power-plug when replacing the fuse or changing line voltage. Replace fuse only by appropriate specified type.

**STATIC ELECTRICITY:** Electronic equipment is sensitive to static discharges. Some input devices such as headstages are equipped with very sensitive FET amplifiers, which can be damaged by electrostatic charge and must therefore be handled with care. This can be avoided by touching a grounded metal surface when changing or adjusting the electrodes. If a headstage is not used the input should always be connected to ground (by using an appropriate connector or with aluminum foil wrapped around the headstage).

**VERY IMPORTANT:** Always turn power off when connecting or disconnecting headstages or other components from the 19" cabinet.

**CURRENT INJECTION HIGH VOLTAGE HEADSTAGE:** The current injection headstage has a  $\pm 45$  V or  $\pm 150$  V output compliance. After turning on the instrument, it must be ensured that the interior contact and the shield of the electrode plug and of the cable which is connected to this plug cannot be touched.

**VERY IMPORTANT:** Always turn power off when changing or adjusting the electrodes.

**TEMPERATURE DRIFT / WARM-UP TIME:** All analog electronic systems are sensitive to temperature changes. Therefore all electronic instruments containing analog circuits shall be used for recordings only in a warmed-up condition (i.e. after internal temperature has reached steady-state values). In most cases a warm-up period of 30 minutes is sufficient.

# 1 INTRODUCTION

## About this Manual

This instructions manual describes the most important functions and operation possibilities of the TURBO TEC-05 and TURBO TEC-10 family of Voltage/Current Clamp amplifiers. A short introduction to the theory and practice of the voltage clamp and current clamp technique is also included, as far as it is necessary for understanding the operation of this instrument. A broad selection of literature, of which we give a selection at the end of the manual, is available on these techniques.

The manual is divided into 8 chapters (0,...,7). Chapter 0 (Safety Regulations) gives some hints for the safe operation of the instrument. Following this chapter (1 Introduction), in the chapter 2 (System Description), the functioning of the device is outlined, followed by chapter 3 (Controls and Connectors), which describes the control switches and displays. The Installation chapter (4) prescribes the calibration and test procedures prior to and at the onset of an experiment. The Control Theory Appendix (chapter 5) describes some theoretical aspects and provides hints for the tuning of the voltage clamp control unit, and in chapter 6 (References) a selection of literature is given. The last chapter 7 outlines the most important technical data of the TURBO TEC amplifiers series.

## Important Literature

An excellent introduction to recording techniques, preparation of oocytes etc. can be found in "Methods in Enzymology, Vol. 207", (see ref. 21) and the chapter (2.19) by Stuehmmer et. al. in ref. 10. The basics of microelectrode techniques and VC principles are described in a comprehensive manner in the "Plymouth Workshop Handbook (Ogden, 1996, see ref. 11). Please refer to chapter 6 (REFERENCES) for a more detailed list of literature or please contact npielectronic.

## Software

The normal experimental situation is the use of a computer-based data acquisition system for controlling the experiment. Nevertheless all TEC systems are designed in a way that they can be used without software. A stimulus generator, digital oscilloscope and chart recorder would be sufficient for working with these amplifiers (see Fig. 4).

All TEC systems can be used in conjunction with the various software packages commercially available. Input and output signals have calibrations that are suitable for most data acquisition packages. They also provide special features such as electronic (remote) selection of modes of operation and monitor (telegraph) signals for the position of current gain and filter switches. Their input and output features as well as the monitor (telegraph) signals provided allow very comfortable interaction between the clamp instrument and the data acquisition package.

If the software CellWorks (available from npielectronic) is used, some of the functions of the TEC systems can be controlled directly from the computer.

## 2 SYSTEM DESCRIPTION

### 2.0 GENERAL DESCRIPTION

The TURBO TEC instruments are voltage/current clamp systems which function according to the classic dual-microelectrode method. This method uses one microelectrode for the registration of membrane potential and one for current injection. The equivalent circuit of a TEC system and the associated block diagram in VC mode are shown in Fig. 1 and Fig. 2. A view of the TEC front panel is given in Fig 3.

Each amplifier of the Turbo TEC series is made up of a 19" basic system with a built-in power supply and two measuring headstages: A smaller one for potential recording and one for current injection and recording.

All TEC systems are based on modern state-of-the-art electronic circuits. Their advanced design makes them superior to other amplifiers. Some of the special features of TEC systems are: differential potential registration, high-voltage current source output, both to eliminate artifacts induced by the use of microelectrodes. TEC systems have automated electrode resistance test modes which can be used even with the electrodes impaled in a cell (see article by Stühmer et. al, Methods in Enzymology, Vol. 207). In addition a unique oscillation shutoff circuit prevents the cell from damage if oscillations occur.

Since the voltage and current clamp techniques are standard techniques of electrophysiology (for a review see Methods in Enzymology, Vol. 207, Smith et al., 1985, or Standen et al., 1987, Kettenmann & Grantyn, 1992, Ogden 1994), only a short procedural description follows based on the diagrams of Fig. 1 and Fig. 2. Terms and abbreviations in capital letters in the text correspond with the labels on the front panel.

### Selection and Options

The following versions are available:

TEC 03X: standard oocyte amplifier (separate manual available)

TEC 03X-CW: special version for CellWorks software

TEC 05X: large cells, muscle, invertebrate cells with fine tipped electrodes, please contact npielectronic for details)

TEC 05CX-CW: special version for CellWorks software

TEC 10X: TEC 10 with digital control of current filter and gain, without transient compensation unit

TEC 10X-CW: special version for CellWorks software

TEC 10CX: TEC 10 with digital control of current filter and gain

TEC 10CX-CW: special version for CellWorks software

### Accessories

TEC systems are delivered with two headstage, power chord, manual and a set of cables / connectors for the reference, ground and the current electrode connector. Special headstages, microelectrode holders and cell models („TEC Cell Model“) are available on request. Please refer to chapter 7 for details or contact npielectronic for details.

## 2.1 POTENTIAL REGISTRATION

### Arrangement of the Recording Electrodes

For membrane potential registration all TEC amplifiers use a differential electrode arrangement to record the membrane potential as accurately as possible (Fig. 1 and Fig. 5). A description of the potential headstage can be found in chapter 3 (3.1).

Two electrodes, an intracellular microelectrode ( $P_{EL}$  = potential electrode) and an extracellular electrode (REF= reference electrode), which are connected to high impedance buffers (input resistance better than  $10^{13} \Omega$ ) in the potential headstage are required for potential measurement. In addition the bath surrounding the cell must have a severe ground connection (Ag/AgCl pellet or Agar bridge, see Fig. 5) which can carry the large membrane currents flowing during voltage clamp experiments. This arrangement ensures the most accurate measurement of the transmembrane potential: the reference electrode (REF) measures the bath potential (extracellular potential) which is subtracted from the intracellular potential recorded by the intracellular electrode ( $P_{EL}$ ). Intracellular microelectrodes used for oocytes have resistances of 300 k $\Omega$  up to 1-2 M $\Omega$ , the resistance of the REF electrode is usually much smaller (a few ten k $\Omega$  maximum).

### Capacity Compensation

The frequency response of the potential electrode (low-pass characteristic) is compensated for by a feedback circuit ("negative capacity" compensation, CAPACITY COMPENSATION, 10-turn potentiometer) and a "driven-shield" arrangement (for an overview see Ogden 1994). The dial is not calibrated and has its zero position on 000. **Since in oocyte experiments microelectrodes are usually in the one M $\Omega$  range or below for most experiments it is not required to use capacity compensation.**

**WARNING:** Capacity compensation is based on positive feedback. Therefore overcompensation causes oscillations (ringing) which can deteriorate the preparation or the recording electrodes. Therefore, the control must be handled with care and before impaling a new cell must be set to 000.

### Offset Compensation

All microelectrodes produce a potential by themselves, the tip potential. This nonlinear and must be compensated electronically. The tip potential of the potential registration microelectrode ( $P_{EL}$ ) is equalized for the most part automatically through the differential potential registration.

The remaining offset is compensated manually by adjusting the offset compensation controls which is available for each electrode (10-turn potentiometers, POTENTIAL OFFSET, approximately  $\pm 200$  mV and CURRENT ELECTRODE OFFSET, approximately  $\pm 500$  mV).

**WARNING:** Offset controls are symmetrical (operating both in positive and negative direction), therefore setting to zero occurs on position 5.00 on the dial. 10 is maximum in positive direction 0 is maximum value on negative direction.

## Current Electrode Potential Recording

In order to determine whether both electrodes are inserted into the same cell, the potential of the current injecting microelectrode ( $C_{EL}$ , see 2.2) is recorded by a buffer amplifier in the current headstage with a  $\times 10$  mV scaling ( $C_{EL}$  POTENTIAL  $\times 10$  mV BNC). This unit is equipped with an offset compensation ( $C_{EL}$ . OFFSET, ten-turn potentiometer,  $\pm 500$  mV).

**WARNING:** Due to the limited operation range of the output amplifier ( $\pm 12$  V maximum) the high voltage signals occurring during current injection will drive this output into saturation (clipping). Therefore during electrode positioning no current flow should occur through the current electrode ( $C_{EL}$ ). During voltage clamp mode the signals at this output may become very noisy.

**WARNING:** The  $C_{EL}$  Offset control is symmetrical (operating both in positive and negative direction), therefore setting to zero occurs on position 5.00 on the dial. 10 is maximum in positive direction 0 is maximum value on negative direction

## Potential Monitor and Audio Monitor

The measured membrane potential is amplified,  $P_{EL}$  by a factor of 10 or 40,  $C_{EL}$  by a factor of ten. The recorded potentials from both microelectrodes ( $P_{EL}$  and  $C_{EL}$ ) can be read out from the respective BNC-sockets (POTENTIAL OUTPUT  $P_{EL} \times 10$  or  $P_{EL} \times 40$ , and  $C_{EL} \times 10$ ), and can also be directly (not amplified) displayed in mV on a digital display. The electrode which is monitored at the display is selected by a toggle switch located at the left side of the display (POTENTIAL ELECTRODE or CURRENT ELECTRODE).

In addition the recorded potentials are converted to a sound with a potential dependent pitch with the AUDIO MONITOR. The electrode which is monitored by the AUDIO MONITOR is also selected by toggle switch POTENTIAL ELECTRODE or CURRENT ELECTRODE.

## 2.2 CURRENT INJECTION AND CURRENT MEASUREMENT

### Current Injection

The current injection is performed by means of a glass microelectrode which is connected to the current headstage ( $C_{EL}$ ). A description of the current headstage is given in chapter 3.2.

The unique advantage of the instruments in the Turbo TEC series is the voltage-controlled current source output (V/C or V/I converter), for electrical compensation of the disturbances from the microelectrode during current injection (i.e. high resistance and stray capacity, see Polder, 1984, Polder & Swandulla, 1990). This current source is built into the current headstage. Due to this current source output, current injection becomes independent from the resistance of the microelectrode which is usually strongly nonlinear. In addition, this circuit allows direct measurement of the current injected in the cell without the necessity of a virtual ground circuit for the bath.

### Output Current Zero (C. HEADSTAGE BIAS CURRENT)

In order to adjust the zero-current of the output current source, each instrument provides a bias current adjustment with a 10-turn potentiometer (ca.  $\pm 0.5\%$  of the current range). The tuning procedure is described in the INSTALLATION chapter.



## Current Injection Bandwidth

On all TEC systems for oocyte recordings, the bandwidth of the current injection electronics can be limited to approximately 10 Hz by means of a switch (BANDW ) on the current headstage (see Fig. 5). This allows the use of a patch clamp amplifier for the recording of channel currents simultaneously to macro-currents recorded with the TEC system without excessive noise from the two electrode clamp loop (see 2.5, Low Noise Mode).

**WARNING:** If the bandwidth of the current headstage is set to 10 Hz, some functions such as  $R_{Cel}$  (current electrode resistance test) do not work properly.

## Capacity Compensation (current electrode, optional)

The TEC-05X amplifiers are equipped with a capacity compensation for the current electrode (CUR. EL. C-COMP., 10-turn potentiometer). This increases the speed of the voltage clamp control circuit when using high-resistance ( $>1\text{ M}\Omega$ ) microelectrodes.

**WARNING:** Capacity compensation is based on positive feedback. Therefore overcompensation causes oscillations (ringing) which can deteriorate the preparation or the recording electrodes. Therefore the control must be handled with care and before impaling a new cell must be set to 0.

## Current Range

Since the resistances of the microelectrodes are in the  $\text{M}\Omega$  range, it is necessary to use a high voltage current source ( $\pm 150\text{ V}$ ) for current injection. The TEC standard version has an output compliance of  $\pm 150\text{ V}$ , i.e. the maximum current is  $150\text{ }\mu\text{A} / 1\text{ M}\Omega$ . The current range of the various TEC versions is determined as follows:

TEC 05X  $150\text{ nA} / 100\text{ M}\Omega$  or  $1.5\text{ }\mu\text{A} / 10\text{ M}\Omega$  (for large cells, e.g. invertebrate neurons)

TEC 10CX  $150\text{ }\mu\text{A} / 1\text{ M}\Omega$  (for very large cells, e.g. oocytes)

Some current headstages are equipped with a switch for the selection of different current ranges (see options, below). For the standard  $150\text{ V}$  headstage the ranges are:

**Option 1** (x0.1, x1, x2, x5):

x0.1 range:  $15\text{ }\mu\text{A} / 10\text{ M}\Omega$

x1 range:  $150\text{ }\mu\text{A} / 1\text{ M}\Omega$

x2 range:  $300\text{ }\mu\text{A} / 500\text{ k}\Omega$

x5 range:  $500\text{ }\mu\text{A} / 200\text{ k}\Omega$

**Option 2** (x0.1, x0.2, x0.5, x1)

x0.1 range:  $15\text{ }\mu\text{A} / 10\text{ M}\Omega$

x0.2 range:  $30\text{ }\mu\text{A} / 5\text{ M}\Omega$

x0.5 range:  $75\text{ }\mu\text{A} / 2\text{ M}\Omega$

x1 range:  $150\text{ }\mu\text{A} / 1\text{ M}\Omega$

**WARNING!!** Always adhere to the appropriate safety measures (see Safety Regulations, Introduction and Installation chapters) when using these instruments. In particular, always shut power off when changing or adjusting electrodes! **Always turn power off when connecting or disconnecting headstages or other components from the 19" cabinet.**

## Current Measurement

The use of the current source output allows that the current is measured en route to the electrode, an improvement in accuracy on the "virtual ground" method, which requires an additional headstage. The current source method also provides an improved frequency response of the voltage clamp control circuit.

## Current Monitor and Current Output Sensitivity

The TEC systems have two current outputs: CURRENT OUTPUT UNCOMPENSATED, the current signal directly obtained from the headstage, (0.1 V/ $\mu$ A, i.e. 1 V at this BNC corresponds to a current of 10  $\mu$ A injected into the cell, standard version). The current from the headstage is also displayed on the digital display (lower display). This signal is amplified and filtered for better presentation giving the CURRENT OUTPUT signal.

The amplification is performed by an amplifier with seven gain factors (from 0.1V/ $\mu$ A...10V/ $\mu$ A which corresponds to an amplification of x1/ x2/ x5/ x10/ x20 /x50 x100). The selection can be set by a rotary switch (CURRENT OUTPUT SENSITIVITY). The following calibrations for the signal at the CURRENT OUTPUT BNC result:

TEC	<u>05X</u> : 0.1, 0.2, 0.5, 1, 2, 5 and 10 V/nA;	display XX.XX nA
TEC	<u>10CX</u> : 0.1, 0.2, 0.5, 1, 2, 5, and 10 V/ $\mu$ A;	display XX.XX $\mu$ A

The position of the CURRENT OUTPUT SENSITIVITY switch is monitored by a DC voltage (1 V / switch position) 1V...7V available at the rear panel (MONITORING OUTPUTS, CURRENT OUTPUT SENSITIVITY BNC connector).

Example: A current sensitivity of 1 V/ $\mu$ A at CURRENT OUTPUT BNC corresponds to a voltage of 4 V at the CURRENT OUTPUT SENSITIVITY BNC connector.

## Transient Compensation (TEC 10CX)

The TURBO TEC 10CX series provides a compensation unit for the suppression of the capacitive currents in the voltage clamp mode (CURRENT TRANSIENT COMPENSATION). For the TURBO TEC-05X the compensation unit is available as a separate instrument for the modular EPMS-07 system (TRC-01M).

Through this compensation unit the voltage clamp pulse is differentiated with three adjustable time constants and added to a linear component to compensate for the leakage current. This signal is subtracted from the measured current signal. The adjustment is made through 4 potentiometers for the amplitudes (A1, A2, A3 and linear) as well as 3 10-turn potentiometers (T1-T3) for the time constants of the differentiators. A BYPASS switch allows to quickly switch off the compensation except the linear component.

## Current Filter

A tunable low-pass (CURR. FILTER) is attached to this amplifier.

The TEC 10CX has a four-pole low-pass Bessel filter with 12 (or 16) corner frequencies: 20, 50, 100, 200, 300, 500, 700, 1k, 1.3k, 2k, 3k, 5k, (8k, 10k, 13k, 20k) Hz. The position of the switch is monitored by the FREQUENCY MONITOR signal (-5...+6V, 1V/step, 12 position filter and -8...+7V, 1 V/step, 16 position filter).

In the TEC 05 it may be a single-pole or a four-pole Bessel filter with 12 or 16 corner frequencies (see TEC 10CX).

## Options

Some of the Turbo TEC instruments have current headstages with four ranges (see also page 10). The TEC-10 model can also be purchased without transient compensation. Please ask npi for details.

### ***2.3 ELECTRODE RESISTANCE MEASUREMENT***

Resistance measurement modes for both microelectrodes ( $R_{pe1}$  and  $R_{ce1}$ ) are included in this device in order to test the function of the electrodes. These test units operate independently of any other adjustments. This is possible under the condition that all microelectrodes are in contact with a grounded bath (zero potential). The measured resistance is independent of tip potentials and is automatically displayed on the digital display in  $M\Omega$ .

The measurement is performed by applying square current pulses of a few nA to the respective microelectrode. The voltage deflection caused by this injection is recorded and processed to give a direct reading in  $M\Omega$  on the digital display. ***The electrode resistance test is also a test of the correct function of the respective headstage.***

**WARNING:** RESISTANCE TEST mode gives only a correct value with high resistance electrodes if the capacity is compensated correctly. Furthermore, with a headstage with four ranges (see above) the RESISTANCE TEST has to be carried out in x1 position. Only in x1 position the value is displayed correctly.

## 2.4 CURRENT CLAMP MODE (CC)

In the current clamp mode, the cell's reaction to current injections is measured. Current injection is performed by means of a current source connected to the current injecting microelectrode, regardless of the electrode resistance (see Fig. 1). Therefore only a current input conditioning unit is necessary for the adequate shaping of the current input signal (COMMAND INPUT). All instruments are equipped for the injection of a constant current (HOLD control, X.XX  $\mu\text{A}$ , adjustable through a 10-turn potentiometer with a digital display), and with an analogue input. The polarity is controlled by a switch, with which the HOLD current signals can also be turned off.

### Current Clamp Inputs

The inputs are analogous to those of the voltage clamp mode: A constant holding current is set on the 10-turn HOLDING potentiometer with a  $\mu\text{A}$  display (X.XX  $\mu\text{A}$ , i.e. max. range is 9.99  $\mu\text{A}$ ). The polarity of the HOLDING control is controlled with the -/0/+ switch. In the 0 position the HOLDING control is turned off. The analogue current input is calibrated with 1  $\mu\text{A}/\text{V}$ , i.e. 1 V generates a current of 1  $\mu\text{A}$ . This input is controlled by an ON/OFF switch.

## 2.5 VOLTAGE CLAMP MODE (VC)

In the voltage clamp mode, the membrane potential is forced by a controller to maintain a certain value or to follow an external command, which allows measurement of ion fluxes across the cell membrane independent of potential changes and separate from capacitive current flows. This is the most complex mode of operation with these instruments. Special precautions must be taken while tuning the control circuit in order avoid stability problems. **IMPORTANT:** Although in VC mode one is primarily interested to record the current flowing across the membrane the clamp circuit controls primarily membrane potential. The better the potential is controlled i.e. the smaller the VC error signal (command signal minus recorded signal) can be made, the more accurate one can record membrane currents. Some theoretical aspects are presented in the *Control Theory Appendix* (see also references).

### Voltage Clamp Inputs

The inputs are analogous to those of the current clamp mode: A constant holding potential is set on the 10-turn HOLDING potentiometer with a mV display. The polarity of the HOLDING control is controlled with the -/0/+ switch. In the 0 position the HOLDING control is turned off. There are two analogue inputs: one is calibrated with 10 mV/mV analogous to the x10 mV potential output and the second is calibrated /40 (x0.025) corresponding to the x40 output. The inputs are controlled with the respective ON/OFF switches.

### Rise Time Control

With application of a pulse, the maximum rise time can be limited with a control. The calibration corresponds to a pulse of 100 mV (1 V on :10 mV command input). The rise time limit is necessary to dampen the overshoots while calibrating the control circuit according to the "symmetrical optimum" (described in the *Control Theory Appendix*).

### Control Circuit (P-I controller)

The TURBO TEC systems are equipped with Proportional-Integral (PI) control loops. These compare the measured membrane potential with the set command potential. The difference is then amplified and integrated by means of an integrator (for details see refs. 5, 12, and 13).

Consequently, amplification of frequencies with a value less than the cut off frequency of the integrator (reciprocal to the time constant) becomes very large, which then positively influences the control process. The resulting signal is used as the command for the current source (see Figs.1 and 2) and determines the current injection, which approaches the set command membrane potential because of the polarity change in the control circuit.

More details about the functioning of the PI controller are given in the Control Theory Appendix 5.1. The proportional gain is set with the potentiometer "GAIN"; the time constant of the integrator is set with the potentiometer INTERGRATOR TIME CONSTANT. The integrator can be shut off with a toggle-switch. In the Control Theory Appendix 5.2, the adjustment of the PI control loop is elaborated. Some considerations concerning the speed of response and linearity are given in Appendix 5.3.

### **VC Error Display**

The recorded membrane potential is compared with the command input signal with a differential amplifier giving the VC error signal. This signal is applied to the controller where it is amplified and fed back into the current source feedback signal). The feedback signal is converted into a current injected through the current electrode into the cell to compensate the ionic fluxes across the cell membrane (symbolically called "active" in Fig. 1 and "Cell activity" in Fig. 2). Under stable conditions the injected current corresponds directly to the ionic movements across the cell membrane. The VC ERROR display shows directly the deviation of the recorded potential from the command signal. For an accurate clamp it must be between  $\pm 0.5$  (max.  $\pm 1$ ).

### **Current Limit (VC OUTPUT LIMIT)**

Under certain experimental conditions, it is necessary to limit the current in the voltage clamp mode (e.g. in order to prevent the blocking of the electrode or to protect the preparation). This is possible with an electronic limiter, which sets the current range between 0-100%.

### **Series Resistance Compensation**

With some preparations, it is not always possible to exclude series resistances, despite differential potential recording (see Fig. 1). These series resistances could cause a current-proportional potential error in the voltage clamp mode, i.e. an unwanted change in the membrane potential during a current flow. This change can be partially compensated by current-proportional amplification in the control circuit. This is done by positive feedback in the control circuit, which can very quickly lead to stability problems. Re-positioning the electrodes is recommendable whenever possible; use this compensation procedure only as a last resort.

### **Low Noise Mode**

TEC instruments can be used in a low noise mode for simultaneous recordings with a patch clamp amplifier. For this purpose the bandwidth of the current source which performs the charge injection into the cell can be limited to 10 Hz by use of the BANDWIDTH Switch located on the current headstage. In this mode the clamp circuit is capable of following only slow changes, i.e. to keep the steady-state.

**IMPORTANT:** The controller must be used in P-mode (INTEGRATOR = OFF) since parasitic oscillations may occur due to the limited bandwidth of the current source (two integral components in a closed loop form an oscillator, see ref. 5 for details).

**WARNING:** If the bandwidth of the current headstage is set to 10 Hz, some functions such as RCel (current electrode resistance test) do not work properly.

## **Improvement of the Control Properties**

Control circuits with negative feedback tend to be unstable as a result of delays inherent in the system (e.g. low-pass characteristics of the microelectrodes) or positive feedback caused by capacitive couplings between the electrodes. With voltage clamp systems, the control properties can be substantially improved by shielding the electrodes from each other. Often the shielding of the potential electrode suffices to reduce the coupling capacity between the electrodes. This shield can be connected to the output of the buffer amplifier ("driven shield" arrangement, see Fig. 1). The correct setting of the C-compensation increases the speed of response of the control loop, but also increases the noise. The correct setting of the different parameters results in a compromise between the stability, accuracy, noise, and control speed. Adjustment criteria, speed of response and linearity are discussed in the Control Theory Appendix (5).

## **2.6. ADDITIONAL SYSTEMS**

### **Audio Monitor**

The membrane potential or the potential of the current electrode can be translated into an acoustic signal (voltage to frequency conversion). Not all instruments are equipped with this device. The signal from both electrodes can be connected to the AUDIO MONITOR, the selection is performed by a toggle switch. The volume can be set by a potentiometer located on the left side of the front panel.

### **Oscillation Shut-Off**

This system shuts off the current injection and the C-compensation if oscillations that might damage the preparation appear. This may happen if the capacity compensation is set at too high levels or if the voltage clamp gain is too high.

The threshold at which the shut-off system is activated can be set in advance with a potentiometer (THRESHOLD). The correct setting must be found by trial and error.

A green light shows the correct function of the amplifier (i.e. normal operation is possible); a red one shows when it has shut down.

If the red light is on the system must be reset with the DISABLE/RESET switch. In the DISABLED position the shut-off function is turned off (green LED on).

**WARNING:** If the red light is on, only the electrode resistance test and the potential registration and display unit work. All other functions of the amplifier are shut off, i.e. it cannot be used any more for VC or CC recordings. In the DISABLED position the green light is always on (i.e. all amplifier functions are activated, if oscillations occur, the preparation may be damaged).

## **2.7 DIGITAL CONTROL UNIT**

All signal in the TEC instruments are selected and commuted by electronic devices (analog switches and multiplexers) which are controlled with digital signals. This allows synchronous switching procedures that avoid switching artifacts and facilitates the use of the instrument. Many functions can also be controlled by computer signals. A digital control interface is available. Please contact npi electronic for details.

### **Mode of operation selection**

TEC-10CX systems: The selection can be made manually or remotely using TTL signals. The selected function is displayed by LED's.

On TEC-10CX systems, the selection of the four operation modes ( $R_{Cel}$ , CC, VC,  $R_{Pel}$ ) can be made with push-buttons, with LED display.

Remote selection can be made with TTL trigger signals applied to the respective inputs (rear panel).

Software selection (optional TEC-10CX-CW, from the CellWorks software package, see Chapter 1) With the ON/EXTERN switch located below the current filter the selection between front panel control (ON) and software control (EXTERN) can be selected.

On TEC-05X systems a 6-position switch is used for the selection of the mode of operation. The active mode is indicated by LED's.

The switch labeled MODE OF OPERATION (located below the displays) is used to select DHC /VC /CC /OFF /BRIDGE or EXTERN mode. DHC and BRIDGE mode are optional.

In the EXTERN mode the mode of operation can be determined by a TTL pulse applied at the MODE SELECT INPUT BNC connector (LO=CC, HI=VC).

If connected to CellWorks the system can be controlled from software.

## 3 CONTROLS and CONNECTORS

### 3.1 FRONT PANEL

A general view of the TEC front panels is given in Fig. 3. The users elements will be described starting from bottom to top from the lower right to left. The current clamp controls and those for adjustment of the current signal are oriented on the right side of the front panel. The keys for the digital control units and the digital display are found in the middle, and the elements for the voltage clamp mode are oriented on the left side of the panel.

HEADSTAGE INPUTS: Plugs for connection of the headstages

POTENTIAL ELECTRODE C. COMP.: Capacity neutralization (potential electrode, current electrode (optional))

POTENTIAL/CURRENT ELECTRODE OFFSET: Offset compensation (potential electrode, current electrode)

CURRENT HEADSTAGE BIAS: Zero setting for the current source (current electrode)

CURRENT OUTPUT FROM HEADSTAGE: Current signal from the current headstage (0.1V /  $\mu$ A)

CURRENT OUTPUT FILTERED: Current output (signal passed through transient compensation (TEC-10CX only), current sensitivity selection amplifier and low-pass filter)

CURRENT TRANSIENT COMPENSATION (TEC 10CX only): Capacitive transient (A1, A2, A3, T1, T2, T3) and leakage current (LINEAR) compensation in voltage clamp mode.

BYPASS / ON. switch. If set to BYPASS the current transient compensation unit is switched off, i.e. amplitude and time constant settings of the transient compensation unit are not working. If set to ON the current transient compensation unit is active. The LINEAR component is not affected by this switch.

**Caution:** In current clamp mode, the a1-a3 and LINEAR controls must be in the zero position.

BATH POTENTIAL (mV) (TEC 05X only): signal at the REF electrode

CURRENT FILTER (Hz): Current output low-pass filter

CURRENT OUTPUT SENSITIVITY: Amplification switch for the CURRENT OUTPUT signal (0.1V/ $\mu$ A - 10 V/ $\mu$ A in seven steps)

HOLDING CURRENT: +/- switch: Holding current control (current clamp mode)

CURRENT STIMULUS INPUT: Current stimulus input in current clamp mode

MODE OF OPERATION (TEC-10CX): Control unit for selection of the operation mode:

R<sub>Cel</sub> - Resistance test of current electrode

CC - Current clamp mode

VC - Voltage clamp mode

R<sub>Pel</sub> - Resistance test of potential electrode

MODE OF OPERATION (TEC-05X): Control unit for selection of the operation mode:

BRIDGE – Bridge mode for potential electrode

CC - Current clamp mode

OFF - In this position the amplifier does not apply any voltage or current to the cell

VC - Voltage clamp mode

EXTERN: if this position is selected, the mode of operation can be set by a TTL pulse applied to the MODE SELECT INPUT (TTL) BNC; LO = CC, HI = VC or DHC (if installed).

DHC – Dynamic Hybrid Clamp mode (option)



DIGITAL DISPLAYS (3 ½ digits):

POTENTIAL/RESISTANCE: membrane potential in mV, resistance in MΩ, with LED's for the selected unit (mV, MΩ):

CURRENT: current in μA

POTENTIAL: Switch for upper digital display

Electrode switch:

POTENTIAL ELECTRODE - Membrane potential or resistance of the potential electrode

CURRENT ELECTRODE - Potential of the current electrode or resistance of the current electrode

OSCILLATION SHUT-OFF: Protection against oscillation of the amplifier

THRESHOLD: Adjustment of the threshold

DISABLED/RESET: Choice of operation, DISABLED = unit is not active.

LED: red: amplifier shut-off; green: turned on/in operation

HOLDING POTENTIAL (mV), -/0/+ switch: Holding potential control in VC mode

VOLTAGE COMMAND INPUT: Command signal in voltage clamp mode (:10 mV or :40 mV)

POTENTIAL OUTPUT P<sub>EL</sub>: (x10 mV or x40 mV): Membrane potential output

POTENTIAL OUTPUT C<sub>EL</sub>: (x10 mV): Potential output of current electrode

COMMAND FILTER TIME CONSTANT: Time constant of the filter for the VOLTAGE COMMAND INPUT (10 μs to 1 ms)

INTEGRATOR TIME CONSTANT - ON/FF switch: Time constant of the integrator of the proportional-integral controller (PI controller)

VC OUTPUT LIMITER (0-100%): Limits maximum current in voltage clamp mode

VC GAIN: Proportional amplification of the PI controller

VC ERROR: Display of control error

SERIES RESISTANCE COMPENSATION / ON switch: Adjustment of series resistance compensation (cur. prop. amplification)

AUDIO MONITOR: Monitors the potential signals

POWER: Power switch

### **TEC-05X option**

Optionally the TEC-05X is equipped with a BUZZ function to facilitate penetration of the cell membrane. BUZZ operation is based on overcompensation of the respective electrode. The electrode for BUZZING is selected via the ELECTRODE RESISTANCE switch.

BUZZ: Push button to activate BUZZ

DURATION: Potentiometer to set the duration of the BUZZ.

TTL REMOTE: BNC connector for connecting a remote switch. TTL high = BUZZ

### **3.2. REAR PANEL**

FUSE (0.63 A/220V, 1.25 A/110V, SLOW): Mains fuse

115/220V AC: Mains cable hook-up through an IEC standard plug

INTERNAL GROUND: System ground

PROTECTIVE EARTH: Mains ground

CURRENT OUTPUT SENSITIVITY MONITOR (1V/STEP; +1 to +7V): signal monitoring the position of the CURRENT OUTPUT SENSITIVITY switch

CURRENT FILTER MONITOR (1V/STEP, -7 to +8V): signal monitoring the position of the CURRENT FILTER switch

### **3.3. POTENTIAL HEADSTAGE**

P<sub>EL</sub>: Electrode connector with "driven shield"

REF: Connection of the reference electrode (for measurement of the bath potential)

GND: Ground connector

#### **TEC-05X option**

The TEC-05X is equipped with a bridge mode. With the electrode connected to the potential headstage the user can penetrate a cell, measure membrane potential and apply current pulses in CC mode. In BRIDGE mode (see MODE OF OPERATION switch) the TEC-05X operates like a single electrode bridge amplifier (see also separate manual).

### **3.4. CURRENT HEADSTAGE**

#### **WARNING!! LETHAL HIGH VOLTAGE**

CURR. EL.: Connection for the current electrode

GND: Ground connector

RANGE (x1/x0.1 or x0.1, x1, x2, x5 or x0.1, x0.2, x0.5, x1) : Selection of the current range (option)

BANDWIDTH (wb/10 Hz): Selection of the bandwidth (see 2.5, Low Noise Mode)

**WARNING:** If the bandwidth of the current headstage is set to 10 Hz, some functions such as R<sub>Cel</sub> (current electrode resistance test) do not work properly.

# 4 INSTALLATION

## 4.1. GENERAL CONSIDERATIONS

### Safety

**IMPORTANT:** Please follow strictly all regulations outlined in chapter 0 (SAFETY REGULATIONS).

In working with the TURBO TEC systems, always adhere to the appropriate safety measures for handling electronic devices. This instrument functions with a high voltage outlet (CUR. EL. plug on the current headstage). After turning on this instrument, it must be ensured that the interior contact of this plug cannot be touched. In addition, it is extremely important that the instrument is turned **off** when changing or adjusting either electrode!

In addition, both headstages contain very sensitive FET amplifiers, which can be damaged with electrostatic charge, and must therefore be handled with care.

Turn power off if headstages are connected or disconnected from the connectors on the front panel of the 19" cabinet.

TEC systems shall be used only in a warmed-up condition to avoid temperature related errors. Before using the TEC systems the output bias current of the current injection headstage must be canceled. The tuning procedure is described in chapter 4 / INSTALLATION (Adjustment of the Current Offset (CURR. OUTPUT OFFSET)).

### Prevention of Line Interference

It is recommended that all experiment should be carried out in a shielded environment (Faraday cage, connected to ground). Such systems are described in the literature (e.g. see refs. 1, 10 and 17). All components inside this shielded area such as microscopes, micromanipulators etc. must also be grounded properly. All electric systems in this area such as lamps, perfusion valves, electrical micromanipulators etc. are sources of noise which may deteriorate the measurement.

All TURBO TEC instruments have a high quality toroid transformer to keep down stray fields. In spite of this, noise problems could occur if other mains-operated instruments are used. The internal system ground (GND socket) should be connected to only one point on the measuring ground, and should originate from the potential headstage. The casings of the headstages are grounded and could be used to make this connection. Multiple groundings (which may form so-called „ground loops“) should be avoided; all ground points should originate from a central point.

**IMPORTANT:** The system ground can be disconnected or connected to the mains ground on the back of the instrument.

## **4.2. TESTS AND TUNING PROCEDURES**

### **General Considerations**

The amplifier must be in the current clamp mode when first turned on.

All systems need a warm-up period of about 20-30 minutes. The instruments should be calibrated and used for measurements only after this time.

All symmetrical offset adjustments have the zero position at 5.00 on the respective scale.

Before turning on the instrument, all offset controls should be set approximately at this position, and all other controls and adjustments should be at zero.

All systems based on feedback circuits such as capacity compensation controls or voltage clamp gain must be on a low position (close to zero) when starting the tuning procedure.

The INTEGRATOR part of the PI controller must be set OFF before switching to VC mode.

### **Basic connections**

The basic connections for testing and using a TEC systems are given in figs. 4-6. The minimum equipment needed is a stimulus unit and an oscilloscope (preferable digital storage scope). Usually a computer based data acquisition system is used for experiments. This is connected in a similar manner (i.e. ADC = analog-to-digital converter to the outputs and DAC = digital-to-analog converter to the inputs of the TEC system).

**For a detailed description of basic set-up construction and necessary equipment please consult the literature (Chapter 6, refs. 1, 10, 11, and 21-23).**

The stimulator or DAC output of the data acquisition system is connected either to the one of the CURRENT STIMULUS INPUT BNCs or the VOLTAGE COMMAND BNCs.

Two input channels of the scope or ADC inputs of the data acquisition system are connected to the CURRENT OUTPUT respectively POTENTIAL OUTPUT of the TEC.

For remote operation through TTL signals or from the computer system connect TTL signals or control cable to the MODE of OPERATION selection BNCs (see 2.7, DIGITAL CONTROL UNIT).

Connect headstages to electrodes or cell model as outlined in figs. 5 and 6.

### **TEC Cell Model**

The testing of the TURBO TEC systems should be performed with appropriate cell models (see Fig. 5 and Fig. 6). For all tests except the CURRENT HEADSTAGE BIAS TUNING procedure the TEC Cell Model must be set „ON“.

We recommend the 100k membrane resistance (see Fig. 6), and the use of square test pulses of 1 V. This corresponds to a command of 1  $\mu$ A in CC mode and to 100 mV steps in VC mode.

### **Adjustment of the CURRENT HEADSTAGE BIAS CURRENT control**

This tuning procedure is very important since it determines the accuracy of the TEC system.

TEC systems are equipped with a high-voltage current source which is connected to the current injecting electrode and performs the current injection (see SYSTEM DESCRIPTION chapter, 2.2). This current source has a high-impedance floating output. Therefore the zero position (i.e. the zero of the bias current) of this device has to be defined.

Since the used high-voltage FET amplifiers become worn from the internal heat dissipation and their characteristics are strongly temperature dependent, the calibration procedure has to be done periodically by the user.

The tuning procedure is done using the C. HEADSTAGE BIAS CURRENT control and a resistance of a few M $\Omega$ . It is based on Ohm's Law: the voltage deflection caused by the output current generated by the headstage on a test resistor is displayed on the digital meter. The output current which is proportional to the monitored voltage deflection is nulled with the C.HEADSTAGE BIAS CURRENT control.

This tuning procedure cannot be performed with an electrode since there always are unknown offset voltages involved (tip potential, junction potentials etc.). Therefore a test resistor of 1-10 M $\Omega$  must be used. If the TEC Cell model is used (see Fig. 6) only the C<sub>EL</sub> and GND (=ground) connectors must be connected. The „ON/OFF(GND) switch can be used for the nulling procedure described below.

First, the connection to the current electrode must be grounded. This can be done directly with the wire connected to the C<sub>EL</sub> connector or if the TEC Cell Model is used, by switching the cell model in the OFF (GND) position.

Now the offset potential of the CURRENT ELECTRODE POTENTIAL output can be nulled. Therefore the digital display is switched to the potential output of the current electrode. (SELECT switch to the left of the upper digital display) and the display is set to zero with the potentiometer C<sub>EL</sub> OFFSET.

Next, a resistance of 1-10 M $\Omega$  is connected from the current headstage output to ground (as if an electrode were attached), or the cell model is switched in the „ON“ position.

The digital display (and the CURRENT ELECTRODE potential connector (C<sub>EL</sub> POTENTIAL OUTPUT /x10m V)) now show a voltage deflection which is proportional to the flowing output current.

The output bias current can be tuned to zero with the C. HEADSTAGE BIAS CURRENT control. The current is zero when the voltage deflection is zero.

As a rule, the current outputs (CURR. OUTPUT UNCOMPENSATED, CURR. OUTPUT) and the CURRENT DISPLAY (lower digital display) should also read 0  $\mu$ A.

This calibration can also be made during an experiment, since no electrode is necessary and the potential reading is not affected.

### **Test of the Current Clamp Mode**

First, the appropriate cell model is set up, followed by the zero-adjustment described above. After this, the offset of the potential electrode is set at zero. If this adjustment is not possible, it is an indication that the input amplifier in the headstage has been damaged by electrostatic charge.

After the offset adjustment, the function of the current clamp can be tested. By application of a holding potential of, for example, 1  $\mu$ A, the membrane resistance must result in an appropriate change in potential (according to Ohm's law).

### **Test of the Voltage Clamp Mode**

After the test of the current clamp mode, the function can be switched to the voltage clamp mode. The control parameters are best adjusted by application of a test pulse. (see Appendix 2, Empirical Tuning Procedure).

After this, the current is measured relative to a given holding potential (for example 100 mV). The measured current should correspond with one calculated by Ohm's law.

## **Testing of the Zero Current / Zero Potential**

After completing these three tests, all input signals should be shut off. All potentials and the current should equal zero in both the current clamp and in the voltage clamp mode.

## **Resistance Measurement**

Test the resistances of the microelectrodes by first switching the MODE OF OPERATION key to the appropriate test system (TEC-10CX) or by switching the ELECTRODE RESISTANCE switch to the desired position.

The function of this system is tested with the most accurate resistances possible. These systems function independently of the other adjustments, with the condition that a connection between the electrodes and ground connector (bath) exists.

If an appropriate display does not appear relative to a given resistance, it is an indication that the input amplifier of the respective measuring headstage has been damaged by electrostatic charge.

## **Adjustment and Test of the Transient Compensation (TEC 10CX)**

This test should be performed after completion of the voltage clamp mode test. With the application of test pulses, it must be possible to suppress the capacitive current to a large extent with the regulators A1-A3 and T1-T3.

The linear „leakage“ current which flows through the resistance of the cell model must be compensated by the "LINEAR" potentiometer.

Note that the BYPASS / ON switch has to be in ON position in order to use the transient compensation.

## **Oscillation Shut-Off**

First, set the DISABLED/RESET switch in the DISABLED position (green light will light). Then set the switch in the middle position, and overdrive the C-compensation to cause oscillations to appear.

The response threshold can now be adjusted with the THRESHOLD potentiometer. If the system responds, the LED will light red, and the current injection and C-compensation are shut off.

In order to adjust the C-compensation to normal, the system can be restored by switching to the RESET position.

After successful completion of these adjustments, the instrument is ready for use. For experimental measurement, follow the same order of procedure: adjustment of the offset compensation in the bath, pre-adjustment of the C-compensation and of the shut-off, and further adjustments after the positioning of the electrodes.

# 5 CONTROL THEORY APPENDIX

## 5.1 THEORY OF OPERATION OF THE TEC SERIES AMPLIFIERS

The standard configuration for voltage clamping oocytes is the two electrode voltage clamp arrangement (19-23). In contrast to previously described clamp systems (for review see ref. 11 and 20) the instruments for oocyte clamping must meet special requirements since oocytes are very large cells with a high membrane capacity (up to 100-500 nF) and large membrane currents (up to 100  $\mu$ A and more).

Voltage clamp instruments are closed loop control systems with two inputs which act from outside on the control loop. An electronic feedback network is used to force the membrane potential of a cell to follow a voltage command (setpoint input) as fast and as accurately as possible in the presence of incoming disturbances (disturbance input, correlated with the activities of the cell) by injecting an adequate amount of charge. The current injected by the clamp instrument is a direct measure for the ionic fluxes across the membrane. (see references 4, 9, 11 and 20).

The performance evaluation and optimal tuning of the system can be done by considering only the command input since the mathematical models (set point transfer function and the disturbance transfer function, see 5 and 10-13) are closely related. Modern control theory provides adequate solutions for the design and optimal tuning of feedback systems (5).

Most voltage clamp systems are composed only of delay elements, i.e. elements which react with a retardation to a change. This type of closed loop systems can be optimized easily by adequate shaping of the "frequency characteristic magnitude" ( $|F(j\omega)|$ ) of the associated transfer function  $F(s)$  (output to input ratio in the frequency domain = **LAPLACE** transform of the differential equation of the system).

Using controllers with a proportional-integral characteristic (PI-controllers) it is possible to force the magnitude of the frequency characteristic to be as close as possible to one over a wide frequency range ("modulus hugging", see 5, and 12-15). This means that the controlled membrane potential rapidly reaches the desired command value.

The PI controller yields an instantaneously fast response to changes (proportional gain) while the integral part increases the accuracy by raising the gain below the corner frequency of the integrator (i.e. for slow signals) to very high values (theoretically to infinite for DC signals, i.e. an error of 0%) without affecting the noise level and stability. Since the integrator induces a zero in the transfer function, the clamp system will tend to overshoot if a step command is used. Therefore the tuning of the controller is performed following optimization rules which yield a well defined system performance (AVO and SO, see below).

The various components of the clamp feedback electronics can be described as first or second order delay elements with time constants in the range of microseconds. The cell capacity can be treated as an integrating element with a time constant  $T_m$  which is always in the range of hundreds of milliseconds.

In comparison with this "physiological" time constant the "electronic" time constants of the feedback loop can be considered as "small" and added to an equivalent time constant  $T_e$ . The ratio of the "small" and the "large" time constant determines the maximum gain which can be achieved without oscillations and thus the accuracy of the clamp. With the gain adjusted to this level the integrator time constant and "small" time constant determine the speed of response of the system.

Tuning of the clamp is performed according to optimization rules: The "absolute value optimum" (AVO) provides the fastest response to a command step with very little overshoot (maximum 4%) while the "symmetrical optimum" (SO) has the best performance compensating intrinsic disturbance signals. The SO shows a considerable overshoot (maximum 43%) to a step command, which can be reduced by adequate shaping of the command pulse by a delay unit (5 and 13). An empirical tuning procedure is given in APPENDIX 2.

The upper speed limit is determined by the maximum amount of current which the clamp system can force through a given electrode (see APPENDIX 3). The clamp performance can be increased considerably if the influence of the current injecting electrode is excluded as far as possible from the clamp loop since the electrode resistance is nonlinear. This is achieved if the output of the clamp system is a current source rather than a voltage source; in this case the clamp transfer function has the magnitude of a conductance (A/V). Other advantages of this arrangement are that the clamp current can be determined by a differential amplifier (no virtual ground is needed, (see 6, 13) and that the bandwidth of the feedback system can be altered easily (e.g. for noise suppression during simultaneous patch clamp recordings, see 19-21).

This output circuit must be equipped with large bandwidth high voltage operational amplifiers. To avoid deterioration of clamp performance caused by electrode overload the output current has to be limited by an electronic circuit to a safe level. With electrodes in the range of one M $\Omega$  and a voltage of  $\pm 150$  V the maximum current will be 150  $\mu$ A. With this current a cell with a capacity of 0.1  $\mu$ F can be depolarized by 100 mV in approximately 100  $\mu$ s, which comes close to the theoretically possible speed of response, without any detectable deviations from the command level. With an output compliance of 225 V and a x2 or x5 range current injecting headstage currents up to 500  $\mu$ A can be injected (see 6 and 15).

The speed of response and the accuracy of a two electrode clamp system is determined by the cell capacity, the resistance of the current injecting microelectrode (which limits the maximum amount of injected current) and the equivalent time constant and accuracy of the potential recording and feedback electronic systems. Therefore the design of the potential recording site is very important. A differential potential registration with a reference electrode which registers the bath potential minimizes errors due to resistances in series with the cell membrane. Driven shield and capacity compensation circuits are used to improve the speed of response.

In some cases, a series resistance compensation circuit which adds a current proportional gain can improve the clamp performance considerably (6). The use of such a circuit enhances the speed of response and improves the accuracy of the clamp system. Since both circuits are positive feedback loops the noise level is also increased.



In addition to the elements of the clamp loop itself the oocyte clamp amplifier needs some additional units which facilitate the work such as electrode resistance test units, oscillation shut-off unit, adequate output signal amplification, filtering and display units, facility for compensating the capacitive currents, etc.

## ***EMPIRICAL TUNING PROCEDURE FOR PI CONTROLLERS***

Before switching to voltage clamp mode all parameters related to the recording electrodes (offset, capacity compensation etc.) have to be tuned in CC mode. With PI controller based clamps capacity compensation tuning can be repeated whenever it is necessary, also in VC mode.

Before switching to VC mode gain control has to be reduced to a safe level, integrator has to be switched off to increase stability.

The PI controller is first used as P controller only (INTEGRATOR switch in "OFF" position). The command input is used without smoothing. Identical command pulses are applied. The gain is increased until the overshoot of the desired tuning method appears. Using only the P part of the controller means that a steady-state error will be present.

Now the I section is reconnected to form the PI controller (INTEGRATOR in „ON“ position). The integrator time constant is set to give the desired overshoot according the optimization rules of Appendix 1.

If the SO is used, an external command input filter has to be used to reduce the overshoot according to the requirements of the experiment.

## ***5.3 SPEED OF RESPONSE AND LINEARITY OF THE CAPACITIVE TRANSIENTS***

For the investigation of voltage activated channels with voltage clamp instruments some special techniques for eliminating the capacitive and leak currents have been introduced, such as the P/4 or more general P/N protocol (see 17 for overview). For these protocols the speed and linearity of response of the clamp system is of great importance.

As outlined in APPENDIX 1 the TEC systems are designed following a control theory procedure called "modulus hugging" (see references 5, 12-16). The procedure requires a PI (proportional-integral) controller. This procedure is applicable to control systems composed of an element with one "large" time constant and many "small" time constants. These "small" time constants can be added to an "equivalent" time constant  $T_e$ .

In case of the TEC control chain the "large" time constant is formed by the cell membrane (several hundred of ms) and the sum of "small" time constants results from the microelectrodes and the electronics (a few tens of  $\mu$ s). Here we consider only the proportional part of the PI controller. We also do not consider possible improvement of clamp performance due to series resistance compensation 6-8, and 20 for details).

### **General Considerations**

For the TEC systems the "small" time constants are at least two orders of magnitude below the "large" time constant:

The "large" time constant is the time constant of the membrane and the equivalent time constant is composed of the time constants of the electrodes, amplifiers etc.

$$T_m = R_m * C_m, T_e = \Sigma T_i$$

The performance of a clamp system can be improved if a voltage controlled current source is used for the current injecting electrode. In this case the very large time constant (hundreds of milliseconds) formed by the electrode resistance and the cell capacity can be ignored since the output of the clamp circuit is a current which flows regardless of the resistance of the injecting microelectrode (see reference 20 for details). Thus the performance of the clamp is no longer depending on the electrode resistance (as long as the current source is not saturated). The clamp gain in this case has the magnitude of a conductance [A/V].

The proportional gain of the clamp system can be calculated as follows (references 5 and 12):

$$K = C_m / 4T_e \quad \text{Linear optimum (LO), aperiodic response, no overshoot}$$

$$K = C_m / 2T_e \quad \text{Modulus optimum (MO), 4\% overshoot, fastest rise time}$$

The gain which should be used in a VC experiment is between these two values. The overshoot can be reduced by low-pass filtering of the command pulse.

The speed of response of the clamp in case of the modulus optimum can be calculated as:

$$T_r = 4.7 T_e, T_s = 8.4 T_e$$

$T_r$  - time until the membrane potential reaches for the first time 100% of the command pulse  
 $T_s$  - time to reach steady state within a tolerance of 2%.  $T_s$  is roughly the duration of the capacitive transient. For a system with dampened overshoot  $T_r$  approaches  $T_s$ .

From these formulas it is clear that the performance of the clamp is determined by  $T_e$ .  $T_e$  is determined by the time constant of the current injecting electrode i.e. by the electrode resistance, stray capacities, cable capacities etc. Shielded cables have capacities of 60-110 pF/m, connectors and pipette holders add a few picofarads. The potential electrode is equipped with a driven shield and a capacity compensation circuit, therefore this time constant is always much smaller than the time constant associated with the current electrode. The time constants of the operational amplifiers can be neglected.

### **Example**

A cable of ca. 10 cm has a capacity of ca. 10 pF, with the stray capacities in the headstage and an electrode resistance of 1 M  $\Omega$  (cell model) this gives a time constant of 10-30  $\mu$ s (corner frequencies of 5-15kHz). With  $C_m = 0.1 \mu$ F and  $T_e = 20 \mu$ s (8kHz bandwidth) the gain can be calculated as:

$$\text{LO: } K = 1.25 \text{ mA/V}$$

$$\text{MO: } K = 2.5 \text{ mA/V}$$

The standard TEC current source has a calibration of 10  $\mu$ A/V. This means that the gain stages related to the GAIN control on the front panel must provide a gain between 125-250. In the TEC system the gain amplifier is composed of two stages: x10 fix and 1-100 variable. The maximum gain of the variable gain stage can be set with an internal trim potentiometer.

If a pulse of 150 mV is applied, the output of the first stage is 1.5V while the second stage goes into saturation if the calculated gain values are used. Therefore the capacitive transients will have large nonlinear components.

A response with no saturation effects is obtainable only with command signals below 100 mV. If larger membrane capacities are used in the cell model, the saturation effects start earlier, because in this case a higher gain is required. To improve this behavior systems with higher output compliance and/or headstages with x2, x5 or x10 ranges must be used, which avoid the saturation effect of the gain amplifier (see references 6), 13), and 14)).

The speed of response (with x1 headstage and 150 V output) from the point of view of control theory is:  $T_r = 94\mu\text{s}$  and  $T_s = 168\mu\text{s}$ .

**Maximum speed of response**

The speed of an ideal VC system is limited only by the maximum current delivered by the current source:

$$[dUm/dt]_{\text{max}} = U_{\text{max}}/(C_m * R_{\text{EL}})$$

$$[dUm/dt]_{\text{max}} = 150\text{V}/(0.1 \mu\text{F} * 1 \text{M}\Omega) = 1500 \text{V/s} = 1.5 \text{mV}/\mu\text{s}$$

To reach 150 mV would last 100  $\mu\text{s}$  provided that the clamp has an ideal characteristic.

Now we can calculate the minimum bandwidth of a real clamp system necessary for "ideal" behavior:

$$T_s = 8.4 T_e = 100 \mu\text{s} \text{ gives } T_e = 12 \mu\text{s}; \text{ BW} = 1/(2\pi * T_e) = 13 \text{kHz}$$

If we assume that  $T_e$  is determined by 70-80% by the time constant of the current electrode (i.e.  $T_{\text{el}} = 10\mu\text{s}$  if  $T_e = 12\mu\text{s}$ ) it is clear that with electrode resistances in the range of 500 k  $\Omega$  the total capacity related to the current injecting electrode can be maximum 20pF. Maximum cable length in this case is 15-20 cm.

A cable of 0.5-1.5 m has a capacity in the range of 50-200 pF. With such a capacity and an electrode resistance of 1 M $\Omega$   $T_e$  is in the range of 50-200  $\mu\text{s}$  and the speed of response would be in a range of 0.5 - 2 ms!

**Conclusions:**

For adequate VC experiments a clamp gain of 1-5 m A/V (i.e. 100-500 internal gain with a current source calibration of 10  $\mu\text{A/V}$ ) is necessary. Therefore with pulse amplitudes of 100-200 mV the operational amplifiers in the gain stages will be saturated causing nonlinear components in the capacitive transients.

The maximum speed of response is determined by the cell capacity, the maximum available current and the command amplitude.

The real speed of response is determined by the time constant associated with the current injecting electrode. It is strongly dependent on the length of the used cable.

***The speed of response and the linearity of the capacitive transients can be improved considerably if a current headstage with a steeper gain (x2 = 20  $\mu\text{A/V}$ , x5 = 50  $\mu\text{A/V}$ ) is used especially in combination with a higher output voltage of  $\pm 225 \text{V}$  (TEC 220 System) and an improved series resistance compensation (see references 2, 6 and 13 and 15).***

## 6 REFERENCES

- Boulton, A.A., Baker, G.B., and Vanderwolf C. H. (eds.), (1990) Neurophysiological Techniques, Basic Methods and Concepts, Humana Press, Clifton, New Jersey.
- Dietzel, I. D., D. Bruns, H. R. Polder and H. D. Lux (1992) Voltage Clamp Recording, in Kettenmann, H. and R. Grantyn (eds.) Practical Electrophysiological Methods, Wiley-Liss, New York.
- Eisenberg, R.S., and E. Engel (1970) The spatial variation of potential near a small source of current in a spherical cell, *J. Gen. Physiol.* 55:736-739
- Ferreira, H.G., and M.W. Marshall (1985) The biophysical basis of excitability, Cambridge University Press, Cambridge.
- Froehr, F. (1985) Electronic Control Engineering Made Easy, An Introduction for Beginners. Siemens AG, Berlin & Munich.
- Greeff, N.G. and H.R. Polder (1997) An optimized, high current oocyte clamp amplifier with ultralinear low-noise response, in Elsner, N. and H. Wässle (eds.) Göttingen Neurobiology Report 1997, Thieme Verlag Stuttgart.
- Greeff, N.G. and H.R. Polder (1998) Optimization of a two-electrode voltage clamp for recording of sodium ionic and gating current from *Xenopus* oocytes. Biophysical Society Meeting (ThPos 238), *Biophysical Journal* (supplement)
- Greeff, N.G. F.J.P. Kuhn and W. Kathe (1998) Gating Currents reveal hidden rat brain IIA sodium channel expression in *Xenopus* oocytes Biophysical Society Meeting (TU-PM-P2), *Biophysical Journal* (supplement)
- Jack, J.J.B., Noble, D. and Tsien, R.W. (1975) Electric Current Flow in Excitable Cells. Clarendon Press, Oxford.
- Kettenmann, H. & Grantyn, R. (eds.) (1992) Practical Electrophysiological Methods, Wiley-Liss, New York.
- Ogden, D (ed.) (1996) Microelectrode Techniques - The Plymouth Workshop Handbook, Second edition, The Company of Biologists Ltd., Cambridge.
- Polder, H.R. (1984) Entwurf und Aufbau eines Gerätes zur Untersuchung der Membranleitfähigkeit und deren Nichtlinearität nach der potentiostatischen Methode (Voltage Clamp Methode) mittels einer Mikroelektrode. Diplomarbeit (M. Sc. Thesis), Technical University Munich.
- Polder, H.R. and Swandulla, D. (1990) Design and Optimal Tuning of Single and Double Electrode Voltage Clamp Systems Using Methods of Modulus Hugging. *Pflügers Archiv* 415:S77.

- Polder, H.R. (1993) Voltage and Current Clamp Methods, in Cellular Signalling, Course Book of the European Summer School at the Marine Biological Laboratory, Helsingør, Denmark.
- Polder, H.R. and K. Houamed (1994) A New, Ultra-High Voltage Oocyte Voltage/Current Clamp Amplifier, in Elsner, N and H. Breer (eds.) Göttingen Neurobiology Report 1994, Thieme Verlag Stuttgart.
- Polder, H.R., R. Schliephacke, W. Stühmer and H. Terlau (1997) A new, switched mode double electrode clamp amplifier avoiding series resistance errors, in Elsner, N. and H. Wässle (eds.) Göttingen Neurobiology Report 1997, Thieme Verlag Stuttgart.
- Rudy B., & L.E. Iverson (eds.) (1992) Ion Channels, Section II.A: Expression of Ion Channels in *Xenopus* Oocytes, Methods in Enzymology, Volume. 207, Academic Press, San Diego.
- Schoepfer, R., A. Föll and H.R. Polder (1996) *EggWorks*: A New Control Software for the Entire Experimental Setup, in Elsner, N. and H.U. Schnitzler Göttingen Neurobiology Report 1996, Thieme Verlag Stuttgart.
- Smart, T.G., and B.J. Krishek (1995) *Xenopus* Oocyte Microinjection and Ion-Channel Expression, from : Boulton, A.A., Baker, G. B., and Walz, W., (eds.), Patch Clamp Applications and Protocols, Neuromethods Vol 26., Humana Press, Totowa, New Jersey.
- Smith, T.G., Jr., Lecar, H., Redmann, S.J., and Gage, P.W. (eds.), (1985), Voltage and Patch Clamping with Microelectrodes. American Physiological Society, Bethesda; The Williams & Wilkins Company, Baltimore.
- Stühmer, W. (1992) Electrophysiological Recording from *Xenopus* Oocytes, in Rudy B., & L.E. Iverson (eds.) (1992) Ion Channels, Methods in Enzymology, Vol. 207, Academic Press, San Diego.
- Stühmer, W., Terlau, H. and Heinemann, S.H. (1992) *Xenopus* Oocytes for Two-Electrode and Patch Clamp Recording, in Kettenmann, H. & Grantyn, R. (eds.) (1992) Practical Electrophysiological Methods, Wiley-Liss, New York.
- Stühmer, W. and A.B. Parekh (1995) Recording from *Xenopus* Oocytes, in Sakmann, B., and E. Neher (eds.) Single Channel Recording, Second Edition, Plenum Press, New York and London.
- Madeja, M., et al (1991) A concentration-clamp system allowing two-electrode voltage-clamp investigations in oocytes of *Xenopus laevis*, J. Neuro. Meth., 38:267-269.
- Madeja, M., et al (1995) Improvement and testing of a concentration-clamp system for oocytes of *Xenopus laevis*, J. Neuro. Meth., 63:211-213.
- Stühmer, W. (1998) Electrophysiologic Recordings from *Xenopus* Oocytes, in P. Michael Conn (ed.) Ion Channels Part B, Meth. in Enzymology Vol. 293, Academic Press, San Diego
- Polder, H.R. and D. Swandulla (2001) The use of control theory for the design of voltage clamp systems: A simple and standardized procedure for evaluating system parameters, J. Neurosci. Meth. 109:97-109

- Kotra, G. and H. Daniel (2001) Bidirectional electrogenic transport of peptides by the proton-coupled carrier PEPT1 in *Xenopus laevis* oocytes: its asymmetry and symmetry, *J. Physiol.* **536.2**:495-503
- Greeff, N.G. and F.J.P. Kühn (2000) Variable Ratio of Permeability to Gating Charge of rBIIA Sodium Channels and Sodium Influx in *Xenopus* Oocytes, *Biophys. Journal*, Vol. **79**, 2434-59
- Babini, E., Paukert, M., Geisler, H. S., & Gründer, S. (2002). Alternative Splicing and Interaction with Di- and Polyvalent Cations Control the Dynamic Range of Acid-sensing Ion Channel 1 (ASIC1). *J.Biol.Chem.* **277**, 41597–41603.
- Jenke, M., Sanchez, A., Monje, F., Stühmer, W., Weseloh, R. M., & Pardo, L. A. (2003). C-terminal domains implicated in the functional surface expression of potassium channels. *EMBO J* **22**, 395-403.
- Paukert, M., Hidayat, S., & Grunder, S. (2002) . The P2X(7) receptor from *Xenopus laevis*: formation of a large pore in *Xenopus* oocytes. *FEBS Lett.* **513**, 253-258.
- Schmitt, B. M. and H. Koepsell (2002) An Improved Method For Real-Time Monitoring of Membrane Capacitance in *Xenopus laevis* Oocytes, *Biophys. J.* **82**:1345–1357.
- Nagel, G., Ollig, D., Fuhrmann, M., Kateriya, S., Musti, A. M., Bamberg, E., & Hegemann, P. (2002). Channelrhodopsin-1: a light-gated proton channel in green algae. *Science* **296**, 2395-2398.
- Estévez, R., Schroeder, B. C., Accardi, A., Jentsch, T. J., & Pusch, M. (2003). Conservation of Chloride Channel Structure Revealed by an Inhibitor Binding Site in ClC-1. *Neuron* **38**, 47–59.
- Rettinger, J. & Schmälzing, G. (2003). Activation and desensitization of the recombinant P2X1 receptor at nanomolar ATP concentrations. *J Gen.Physiol* **121**, 451-461.
- Verri, T., Kottra, G., Romano, A., Tiso, N., Peric, M., Maffia, M., Boll, M., Argenton, F., Daniel, H., & Storelli, C. (2003). Molecular and functional characterisation of the zebrafish (*Danio rerio*) PEPT1-type peptide transporter. *FEBS Lett.* **549**, 115-122.

# 7 TURBO TEC SERIES SPECIFICATIONS

All following current signal related parameters are for the TEC 05 and TEC 10 instruments with standard 150 V current headstage

Parameters for the other systems or for systems with a selectable current ranges can be calculated from these parameters.

## MODES of OPERATION

DHC Dynamic Hybrid Clamp Mode (TEC-05 option); CC Current Clamp Mode; VC Voltage Clamp Mode; OFF Mode; BRIDGE Bridge Mode (option TEC-05)

MODE selection: 6-position toggle switch (TEC 05), or pushbuttons (TEC 10), LED indicators; remote selection by TTL inputs.

## ELECTRODE RESISTANCE test

POTENTIAL ELECTRODE: measurement of the ELECTRODE RESISTANCE of the POTENTIAL ELECTRODE

CURRENT ELECTRODE: measurement of the ELECTRODE RESISTANCE of the CURRENT ELECTRODE

## HEADSTAGES (TEC-10)

Potential headstage:

Differential input (for suppression of bath potentials),  $\text{cmr} > 80 \text{ dB}$ ; Input resistance:  $>10^{13} \Omega$ ; operating voltage  $\pm 15 \text{ V}$ .

Electrode connector: BNC with driven shield; driven shield range:  $\pm 15 \text{ V}$ , output impedance  $250 \Omega$ .

Reference connector (bath) gold-plated SUBCLIC, grounded shield; ground connector: 2.3 mm connector or headstage enclosure.

Size: 65x25x25 mm, headstage enclosure is connected to ground.

Holding bar: diameter 8 mm, length 10 cm.

Current headstage (high voltage):

Operating voltage range :  $\pm 150 \text{ V}$  (standard, TEC-10) or  $\pm 225 \text{ V}$  (TEC 225 systems); input resistance:  $>10^{12} \Omega$  (internally trimmable); electrode connector: gold-plated SUBVIS connector, grounded shield.

Power dissipation: 6 W (standard system) or 20 W (TEC 225 system).

Size: 100x50x30 mm with heat sink 100x50x20 ( $< 150 \text{ V}$ ) or 225x40x60 mm or equivalent (TEC 225), grounded enclosure; holding bar (isolated from ground, standard system only): diameter 8 mm, length 10 cm.

Current range:

150  $\mu\text{A}$  / 1 M $\Omega$  (TEC 10CX) oocyte systems)

220  $\mu\text{A}$  / 1 M $\Omega$  (TEC 225)

Current range switch (optional): - x2, x5, x10, or x0.1; - x0.1, x0.2, x0.5, x1

Current headstage (TEC-05):

see additional information sheets

#### Bandwidth and Speed of Response:

Full power bandwidth ( $R_e = 0$ ) :  $> 100$  kHz; rise time (10-90%, current pulse of  $100 \mu\text{A}$  applied to  $R_e = 1 \text{ M}\Omega$ )  $< 30 \mu\text{s}$ ;

Bandwidth switch: wide band or  $10$  Hz for parallel patch clamp recordings

#### Current Electrode Parameter Controls:

Leakage current: adjustable to zero with ten-turn control; offset compensation: ten-turn control,  $\pm 1200 \text{ mV}$ ; capacity compensation (optional, TEC 05X range  $0$ - $30 \text{ pF}$ , ten turn potentiometer.

#### Potential Electrode Parameter Controls:

Capacity compensation: range  $0$ - $30 \text{ pF}$ , ten turn control; offset compensation:  $\pm 200 \text{ mV}$ , ten-turn control.

#### POTENTIAL OUTPUTS:

Potential electrode: two outputs, sensitivity  $\times 10 \text{ mV}$  and  $\times 40 \text{ mV}$ , output impedance  $250 \Omega$ ; output voltage range  $\pm 15 \text{ V}$ .

Current electrode: sensitivity  $\times 10 \text{ mV}$ ; output impedance  $250 \Omega$ , output voltage range  $\pm 15 \text{ V}$ .  
DISPLAY (switch selected):  $\text{XXX mV}$ .

#### AUDIO MONITOR:

Pitch correlated with potential signals, switch selected.

#### OSCILLATION SHUT-OFF:

Turns off current injection and capacity compensation, function displayed by red/green LED, disabled /off/reset switch, threshold set with linear control ( $0$ - $1200 \text{ mV}$ ).

#### ELECTRODE RESISTANCE TEST (both electrodes):

$100 \text{ mV} / \text{M}\Omega$ , obtained by application of square current pulses  $\pm 10 \text{ nA}$ , display  $\text{XX.X M}\Omega$ , selected automatically.

#### CURRENT OUTPUTS:

Uncompensated output signal: sensitivity  $0.1 \text{ V}/\mu\text{A}$ , output resistance  $250 \Omega$ , output voltage range  $\pm 15 \text{ V}$ .

Compensated /filtered output: sensitivity:  $0.1 \dots 10 \text{ V}/\mu\text{A}$  in 1-2-5 steps, selected by rotary switch, with lowpass Bessel filter, output impedance  $250 \Omega$ ; sensitivity monitor:  $1 \dots +7 \text{ V}$ ,  $1 \text{ V} /$  switch position, output impedance  $250 \Omega$ , DISPLAY:  $\text{X.XX } \mu\text{A}$ .



#### CURRENT SIGNAL PROCESSING:

TEC 10: transient compensation unit with three overlapping ranges, (max: T1 = 3.3 ms, T2 = 330  $\mu$ s, T3 = 33  $\mu$ s), time constants set with ten-turn controls, amplitudes set with one-turn linear controls, leakage compensation maximum 1  $\mu$ A.

#### CURRENT OUTPUT FILTERS:

TEC 05X: two-pole (standard version) or four-pole lowpass Bessel filter (TEC 05X-BF system) with 16 corner frequencies, 20 Hz - 20 kHz; frequency monitor: -8...+7 V, 1 V / switch position, output impedance 250  $\Omega$ .

TEC 10CX: four-pole lowpass Bessel filter with 16 corner frequencies, 20 Hz - 20 kHz; frequency monitor: -8...+7 V, 1 V / switch position, output impedance 250  $\Omega$ .

#### CURRENT CLAMP (TEC 10, standard current headstage):

Inputs: 1  $\mu$ A/V, 0.1  $\mu$ A/V with ON/OFF switches, input resistance > 100 k  $\Omega$ ; HOLD: X.XX nA, ten-turn digital control with -/0/+ switch, maximum 10  $\mu$ A.

For TEC-05X see separate sheets

Noise: potential output: 100  $\mu$ V pp; current output 200 pA pp with 1 M  $\Omega$  resistance and 10 kHz bandwidth (internal four-pole Bessel filters).

Speed of response (1% settling time; potential output signals after application of square pulses of 1V with 1 M  $\Omega$  electrode resistance): potential electrode < 10  $\mu$ s, current electrode < 50  $\mu$ s.

#### VOLTAGE CLAMP:

Inputs: two inputs with ON/OFF switches, sensitivity :10 mV and :40 mV, input resistance > 100 k $\Omega$ ; HOLD: XXX mV, ten-turn digital control with +/0/- switch, maximum 1000 mV.

RISE TIME LIMIT: 0-0.2 ms

GAIN: 10  $\mu$ A/V - 10000  $\mu$ A/V, ten-turn linear control.

INTEGRATOR TIME CONSTANT: 200  $\mu$ s - 2 ms, ten-turn control.

OUTPUT CURRENT LIMIT: 0-100% linear control.

NOISE (filters set to 10 kHz, other settings see below)

Potential output: < 100  $\mu$ V pp, current output: < 10 nA pp at 10 kHz, < 2 nA at 500 Hz

#### SPEED of RESPONSE (VC Mode):

1 % settling time: < 80  $\mu$ s for 10 mV step and < 100  $\mu$ s for 100 mV step applied to cell model ( $R_{EL}$  = 1 M  $\Omega$ ,  $R_m$  = 100 k  $\Omega$ ,  $C_m$  = 0.1  $\mu$ F, standard headstage); < 80  $\mu$ s with 225 V headstage.

POWER REQUIREMENTS: 115/230 V AC, 60 W (1.25/0.63 A fuse, SLOW)

#### DIMENSIONS:

19" rackmount cabinet, 19" (483 mm) wide, 14" (355 mm) deep, 5.25" (132.5 mm) high, weight 11 kg

**ACCESSORIES PROVIDED:**

Potential headstage, standard current headstage (other headstages may be substituted on request with order)  
Cable set and connectors for reference, current electrode, and ground connectors  
Power cable  
Operation manual.

**OPTIONAL ACCESSORIES (ordered at additional cost):**

TEC-MOD: passive model cell; -ODA: active model cell.  
High voltage headstage with four current ranges.  
TEC-EH-SET: electrode holder set  
TRC-01M (TEC 05X systems only): Current transient compensation module for TEC 05 amplifiers.

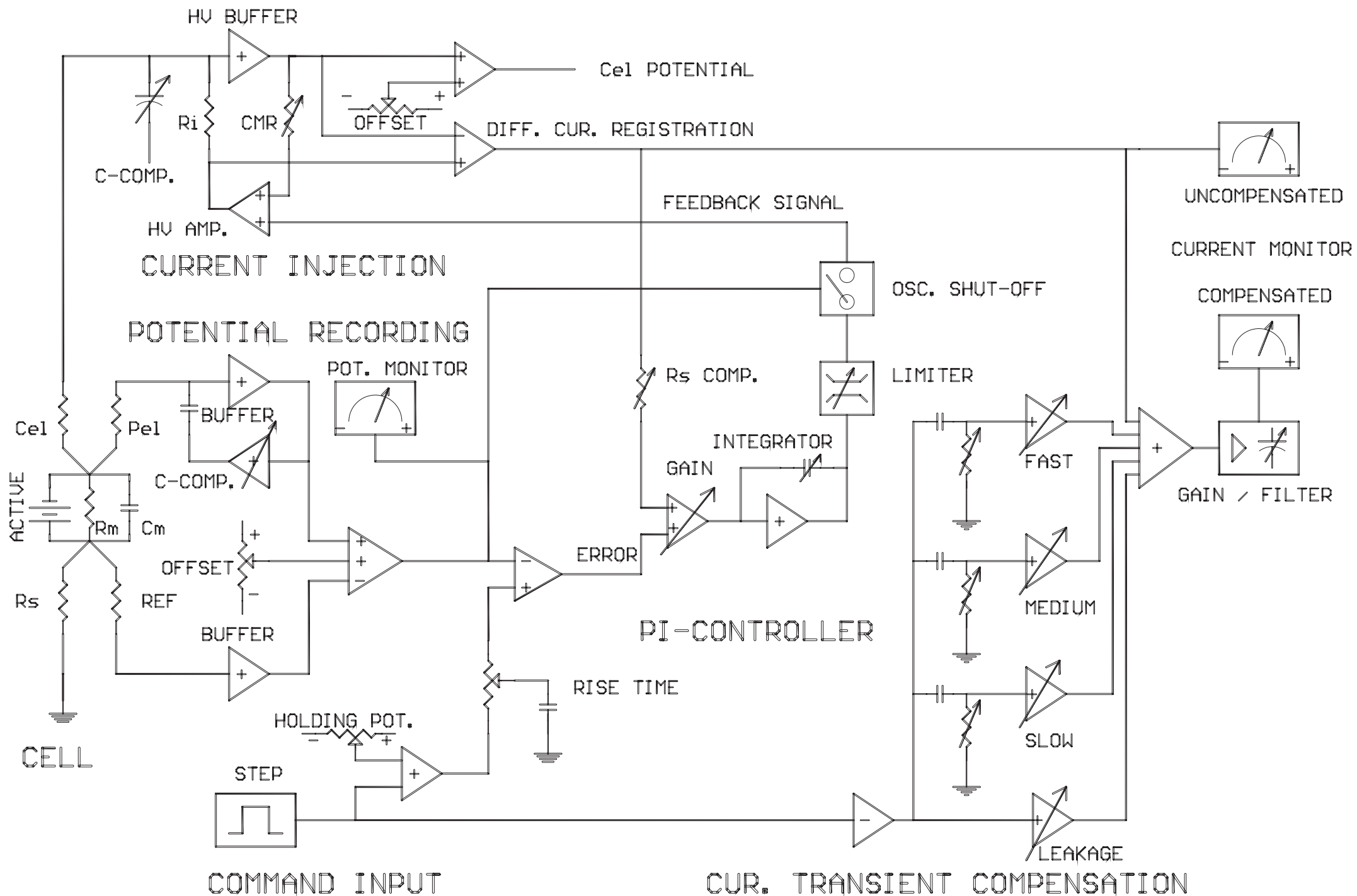

**FIG. 1** Equivalent Circuit Diagram of TEC 10 Voltage Clamp System

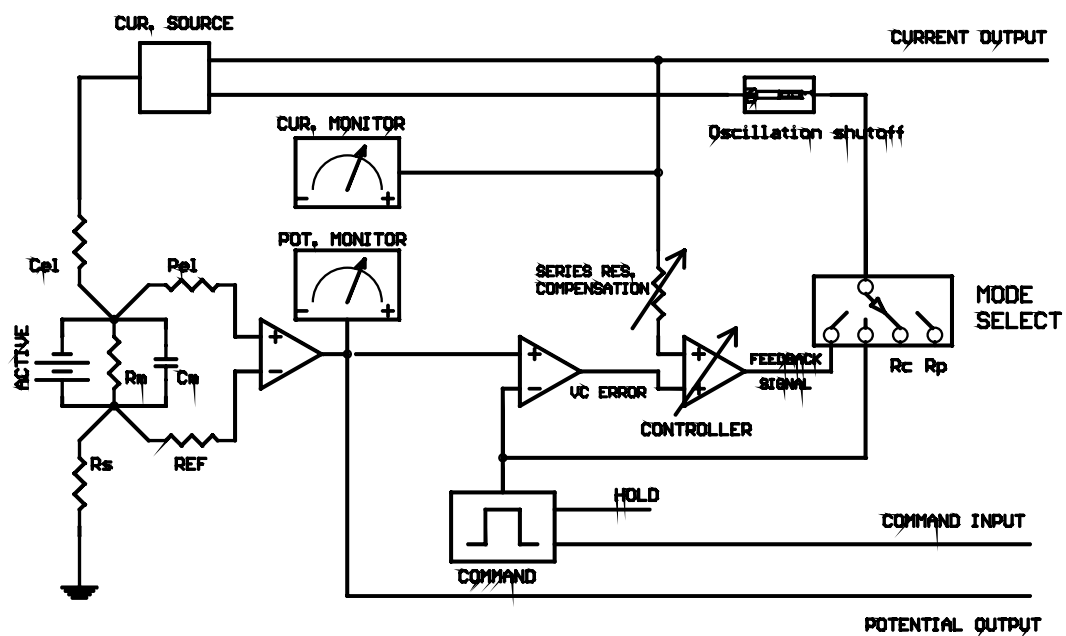

Fig.2A EQUIVALENT CIRCUIT OF TEC AMPLIFIER

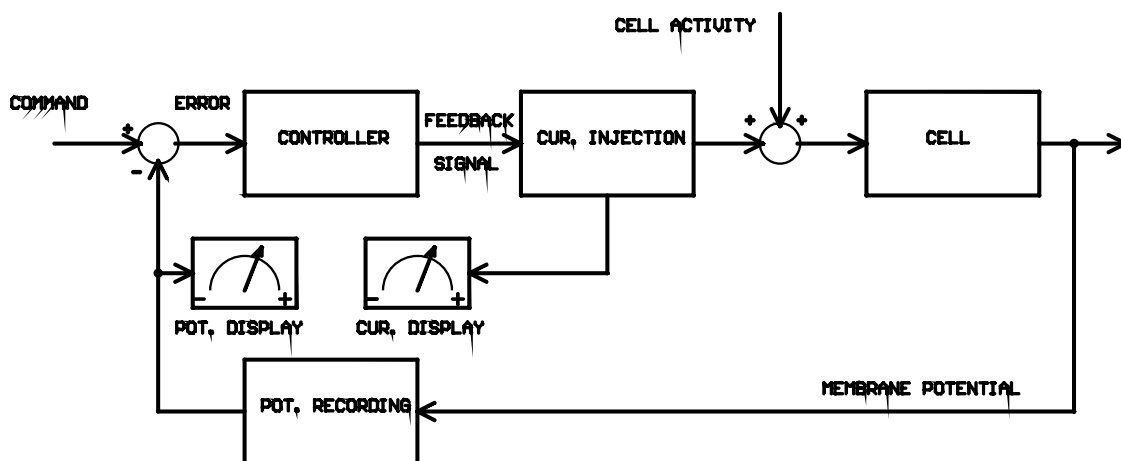

Fig.2B BLOCK DIAGRAM OF VC MODE



Fig. 3: TEC-10CX Front Panel

FIG. 4 CONNECTIONS

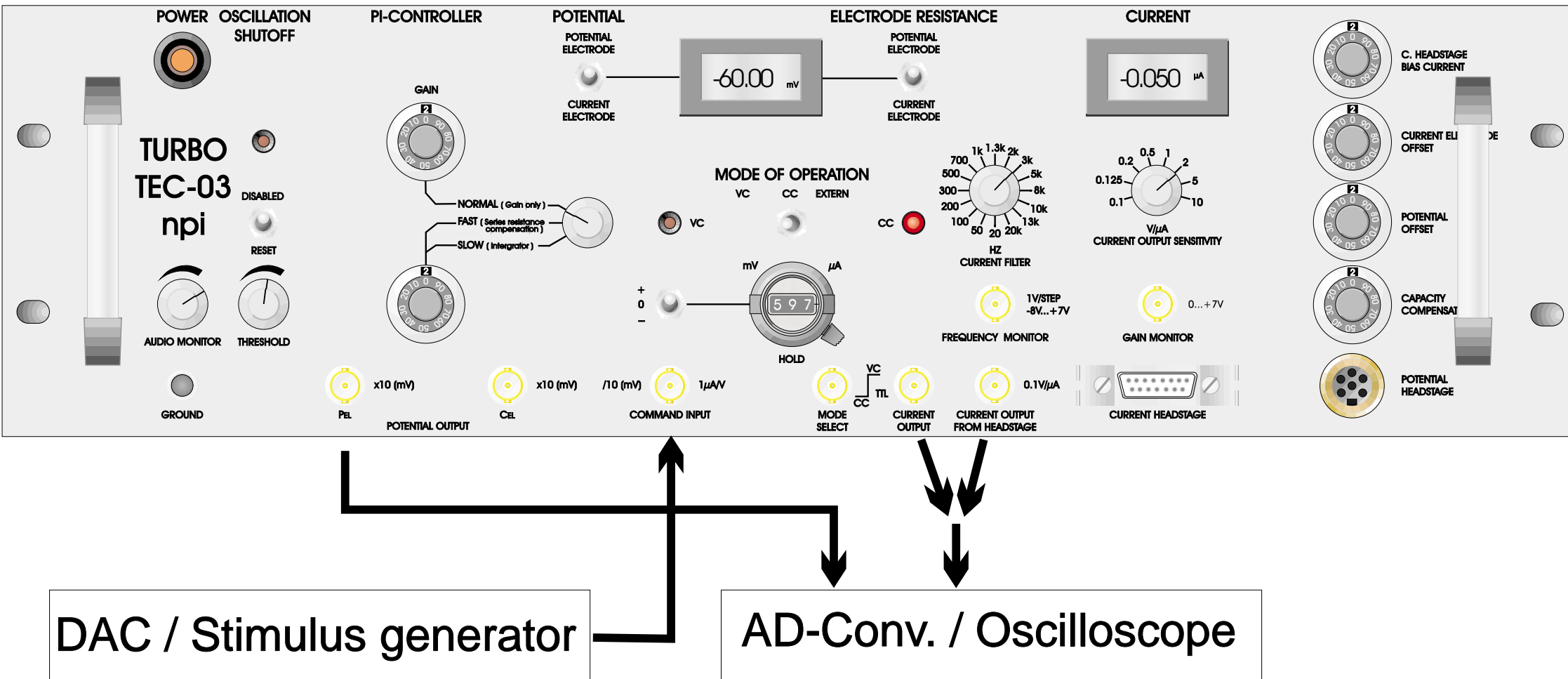
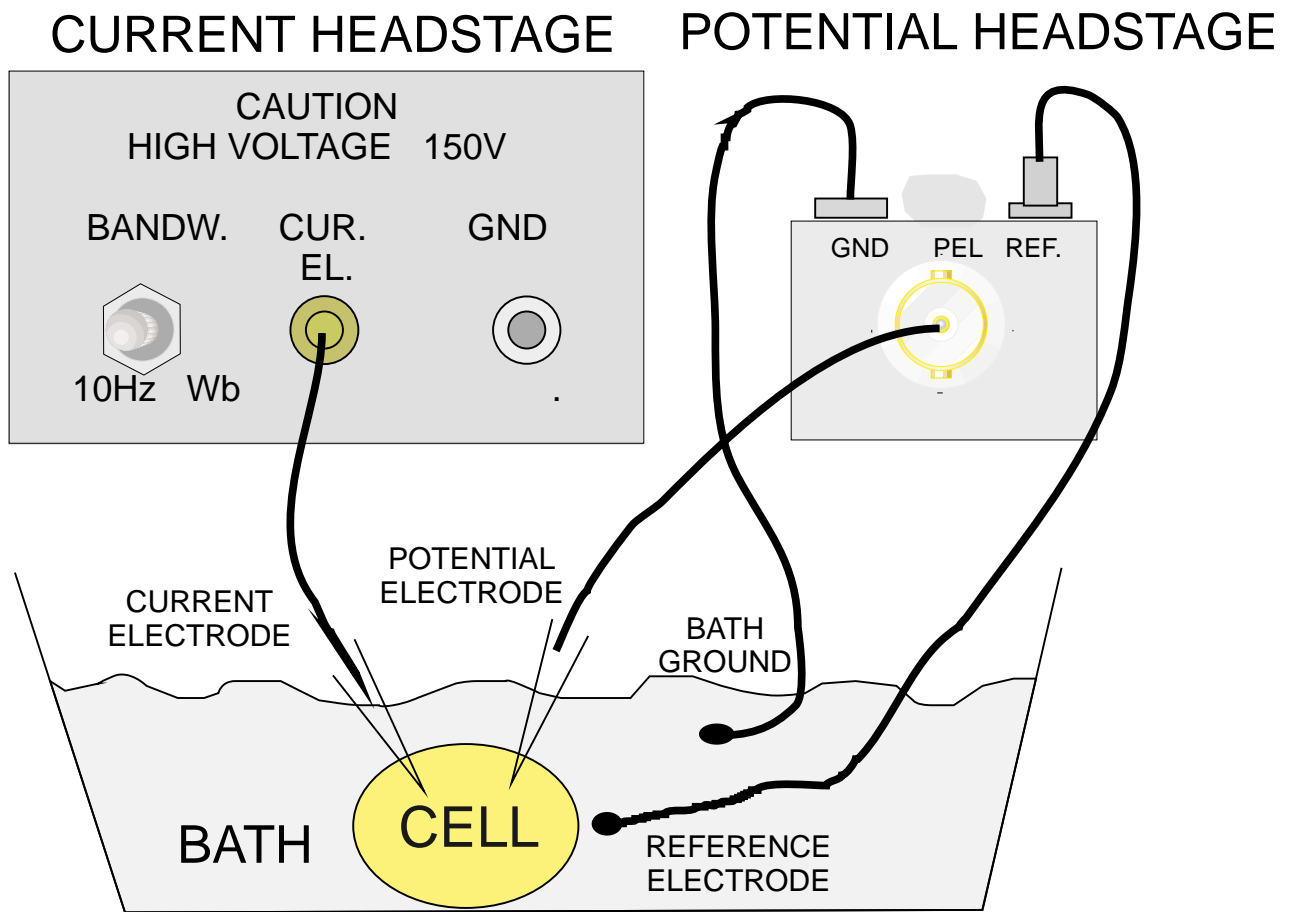

FIG.5 HEADSTAGE CONNECTIONS



Potential Electrode

Current Electrode

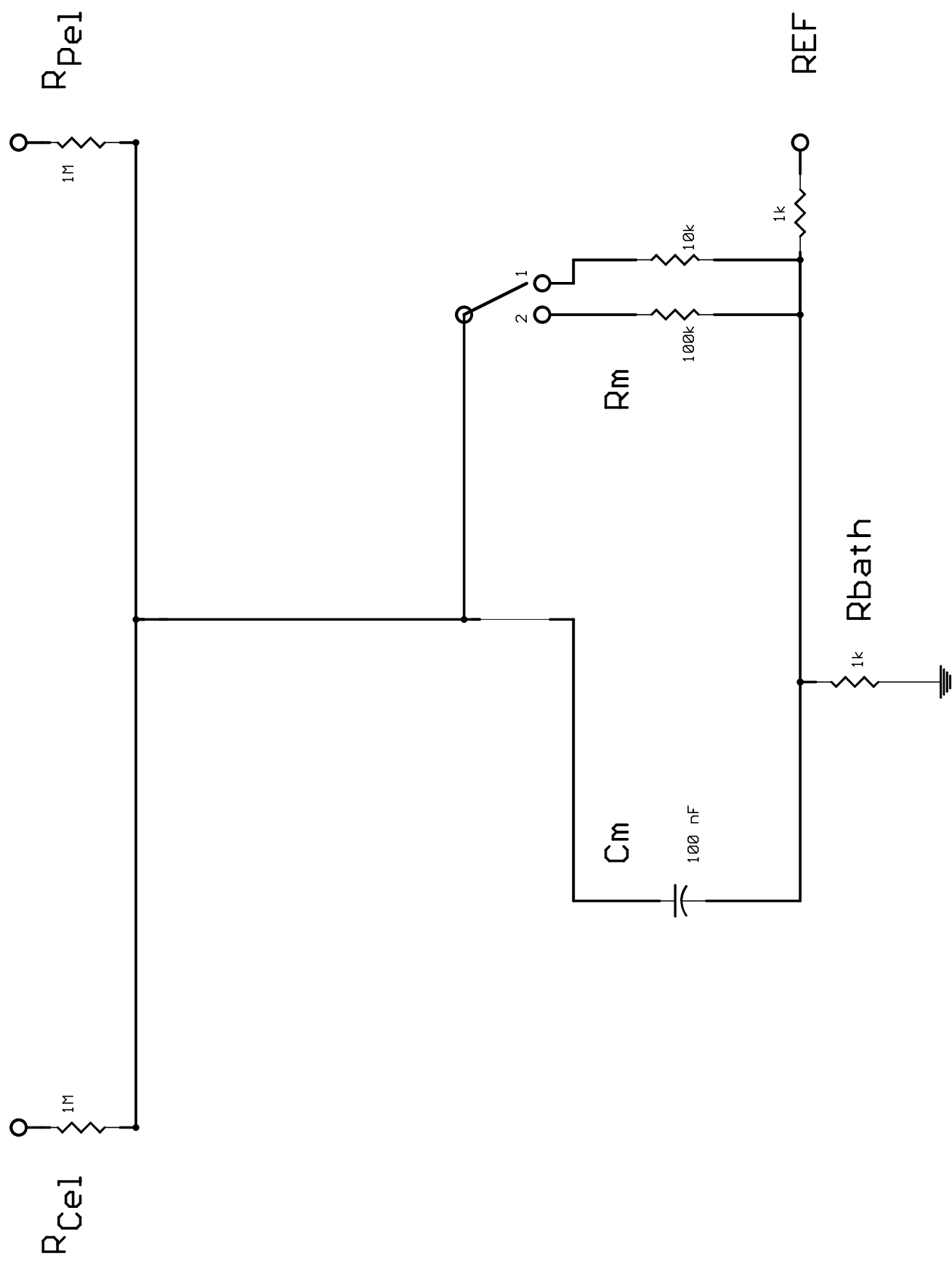

Fig. 6 TEC CELL MODEL